

Der Virtuoso.



For Perusal Only

für
Piano solo
~ visuals optional

Timothy A. Kramer 1987

Der Virtuos - piano and optional visuals, 1987

(timing: ca. 16'00")

Der Virtuos is based on a series of caricatures by Wilhelm Busch. Busch highlights and expands the different musical sentiments of a Lisztian, virtuosic pianist. Although each drawing has its own character and musical personality, there is also a musical form which is independent from the visual accompaniment. (The work may also be performed without slides.) This musical form is controlled by two principal ideas: a semi-tone wedge which contracts and expands to a tritone and a "fixed idea" of a simple tune. The "wedge" is first presented in a varied form in the introduction and later surfaces in its kernel form as the subject of the 'fuge del diavolo'. The fixed tune is most prominently heard as the melody of the adagio, but also appears as the countersubject of the fugue. The appearance of the fugue marks both a structural and dramatic climax. The ensuing episodes develop material from the first half of the piece and push the pianist to virtuosic extremes.

For Perusal Only

PERFORMANCE NOTES

1. This composition is based on a series of drawings by Wilhelm Busch. Their humorous character, presenting different dimensions of the virtuoso pianist, should not be represented in a tongue-in-cheek manner; rather, the performer should seriously consider and convey each appropriate mood and seek to be the inherent humor to reveal real and meaningful ideas.
2. To aid in this idea, and to reveal more clearly to the audience the musical impetus for the work, slides of each drawing may accompany the music. Each slide should remain on the screen throughout its corresponding movement. The slides must be presented with two projectors with a variable-speed dissolve unit. There are 17 slides in all: 15 for the drawings and 2 blanks. They may be obtained from the composer upon request. Indications for changing the slide frames, as well as the length of panning-time between frames (using the dissolve unit), are indicated in the score.

1	(title DER VIRTUOSO)
2	Silentium
3	Introduzione
4	Scherzo
5	Adagio
6	Adagio in sentimento
7	Piano
8	Scherzando
9	(blank white)
10	Maestoso
11	Capriccioso
12	Passagio chromatico
13	Fuga del diavolo
14	Forse vivace
15	Fortissimo vivacissimo
16	Finale furioso
17	Bravo - Bravissimo

For Example:

This $\boxed{2}-3''$ indicates that frame, $\boxed{2}$, is on at the first arrow but appears completely without the first frame, $\boxed{1}$, after a 3 second dissolve.

Even numbered frames are placed in one projector, odd numbered frames in another.

3. Although the slides will add a sense of theater to the performance, the performance should remain primarily musical. The piece is essentially independent of the visuals and may be performed without visual accompaniment. The program should list the movements as above - not the tempo / character indications.

For Perusal Only

Der Virtuoso.

Timothy A. Kramer 1987

1 → this frame should be on after house lights are off and as performer enters, then, after the performer is seated...

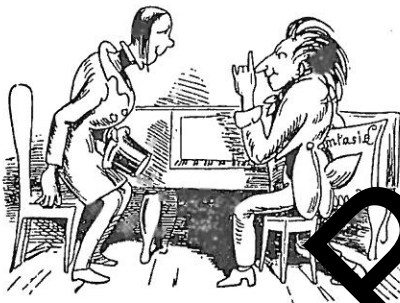

Silentium.

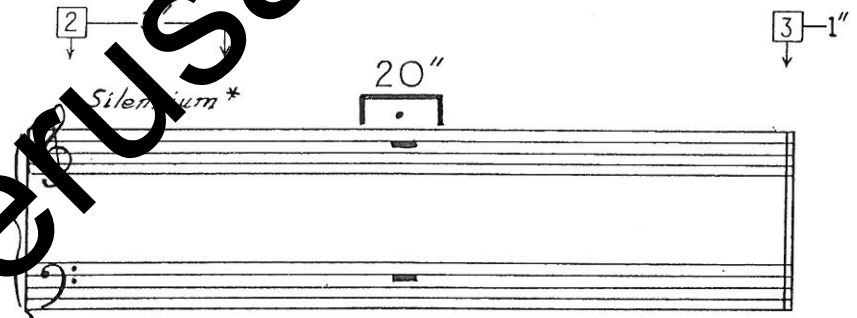

* After sitting down, place yourself in a comfortable playing position. Remain very still until the audience has your complete attention and there is nearly an unspoken sense of urgency for you to begin to play. This may take between 15 to 30 seconds, depending on the hall. Then turn the page quietly and slowly, and begin the intro...

copyright © 1987, by Timothy A. Kramer



Introduzione.

Grandioso ma non troppo (♩ = ca. 58)

Handwritten musical notation for the beginning of the piece, including dynamic markings like *ff* and *p*, and articulation marks.

Handwritten musical notation for the first system, featuring complex rhythmic patterns and dynamic markings.

Handwritten musical notation for the second system, including performance instructions like *clear* and *1/2 clear*.

Handwritten musical notation for the third system, with dynamic markings such as *p* and *una corda*.

Handwritten musical notation for the fourth system, including the instruction *tre bells, but still subdued.* and dynamic markings like *mp espress.* and *mf*.

FOR PERUSAL ONLY

poco rubato

cresc.

(Ped.)

a little slower (♩ = 54)

sotto voce

cantabile

f

cresc.

ff

delicato

molto rit.

dim.

mf

P

Tempo Prima

again, like bells...

una corda

tré corde

2pp

P

una corda

8va bassa

(Ped.) →

*

Make this page-
turn a musical
part of the next
movement...

FOR PERSAL ONLY



Scherzo.

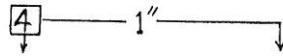

Delicate and Bouncy (d. = 116)

Bva →

with a "piano-bar" dreaminess

(poco)

p poco cresc. - -

poco rit. - - - a tempo

mf mp sub f

$\frac{1}{2}$ (full) clear

FOR PENSAL ONLY

sub mp cresc.

f sub p sub. f mp (secco)

mf p mp pp dim. smorz. poco rit. una corda clear

sub. ff sub. mp tre corde

f cresc. poco a poco ff

sub.p cresc. - - - - - f

subp — sfp — sfp sfp — sfp

cresc. - - - - - sf — - - - - sf

3 sub.p 4 mf ff mf

poco - a - poco - - - - - tardando - - - - - dolce - - - - - d. = ca. 56 5 - 3" *

Sos. → una corda

* This cadence should feel "open", leading to the next movement.

→ Hold Sos. through the pageturn...



Adagio.

Peaceful; Restful. (♩ = ca. 60)

3
4 *p*

... release Sos.

cantabile *p* *mp* *espre*

1/2 clear (full)

1/2 clear

p *mp* *p*

cresc. *mf* *mp* "smooth"

1/2 clear (full) 1/2 clear (full)

poco rit. - - *slighty passionate* (♩ = ca. 64)

dim. *p* *mf*

12

First system of musical notation. Treble clef, key signature of two flats. Features a *poco* marking and a *dim.* marking. Includes a triplet of eighth notes and a slur over a group of notes.

Second system of musical notation. Treble clef. Features a *cresc.* marking, a *mf* dynamic, and a *cantabile* instruction. Includes a *8va* marking and a slur over a group of notes.

Third system of musical notation. Treble clef. Features a *allarg.* marking, a *tempo primo* marking with a tempo of $\text{♩} = 60$, and a *dim.* marking. Includes a triplet of eighth notes.

Fourth system of musical notation. Treble clef. Features a *poco rit.* marking, a *a tempo* marking, and a *"smooth"* instruction. Includes a *mf* dynamic and a triplet of eighth notes.

Fifth system of musical notation. Treble clef. Features a *calmo* marking, a *poco rit.* marking, and a *pp* dynamic. Includes a *dim.* marking and a *attacca* instruction. The system ends with a double bar line and a 5/4 time signature.

Turn page quietly...



Adagio con sentimento.

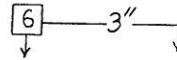

Dripping With Sentiment ($\text{♩} = 92$)

a tempo
mf *passionato*

rit. - - a tempo *rit. - - - a tempo*

poco rit. - - a tempo *rit. - - -* *poco agitato*

mp *p* *mp cantabile*

(♩ = 50) *delicato* *poco rit.* *a tempo* *poco rit.*

p *mp* *dim. - - p*

$\text{♩} = 46; \text{♩} = 92$ *rall. - -* *with newly attempted passion* *a tempo (♩ = 46)* *accel.*

dim. - - pp *p* *mp* *cresc.*

$\text{♩} = 50$ *molto rit.* *Largo* ($\text{♩} = 44$) *still firm*

mf *poco* *dim.* *p* *mf*

Grave ($\text{♩} = 36$) *cresc.* *f* *dim.* *mp* *p* *attacca*

v. let up Ped. slowly to...

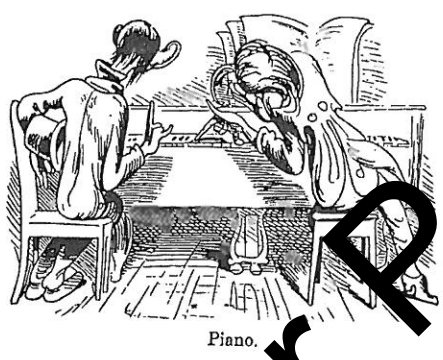

Flooding ($\text{♩} = \text{ca. } 60$) *P*

$\frac{1}{2}$ to $\frac{1}{4}$ Ped. throughout (5" decay)

a tempo $\text{♩} = 72$ *8va*

$\frac{1}{2}$ to $\frac{1}{4}$ Ped. →

* Use most convenient fingering.

V.S.

The musical score consists of five systems of two staves each. The first system features a treble clef with a 3/8 time signature and a bass clef with a 4/4 time signature. It includes a *3(p)* marking and a $(\frac{3}{2} \text{ to } \frac{1}{4} \text{ Ped.}) \rightarrow$ instruction. The second system has a *1 pp* marking in the treble and a *3 p* marking in the bass, with *una corda* and *tre corde* instructions. The third system includes an *8va* marking. The fourth system features a *(loco)* marking. The fifth system includes *rit.*, *a tempo*, *lontano PP*, and *p* markings, along with *una corda* and *tre corde* instructions. A large watermark 'FOR PENSAL ONLY' is overlaid diagonally across the page.

(loco)

($\frac{1}{2}$ to $\frac{1}{4}$ Ped.) →

14 14

5
4

8 — 3''

5
4

3
4

attacca

For Perusal Only

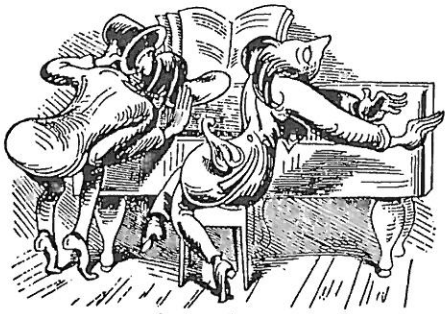

Smorzando.

Feather-light (♩ = 108)

una corda
($\frac{1}{2}$ to $\frac{1}{4}$ Ped.) →

* Using the fingernails only of the right hand, play like a white-note arpeggio. A clicking noise should result; no pitches should sound! The left hand should follow closely behind the right, not touching the keys, for the proper visual effect.

pp
 (1/2 to 1/4 Ped.) → (una corda)
 PPP

8va
 (ppp)
 smorz. (8va)
 smorz.

8va
 *no pitch
 (ppp)

* like before, with fingernails. (see note, bottom of page 14.)

9
 (15ma) → 5"
 poco rit.

△ Without touching the keys, move your hands over the highest register of the keyboard and off to the right of the keyboard into the air — as if you are playing (and you are!) still softer (ppppp) and higher. Wiggling fingers, to imitate pressing the keys, is an option. Be dramatic.

hold hands in final position ... ca. 5" ... slowly turn page (ppppp!)

(1/2 to 1/4 Ped.) →

attaccq

*

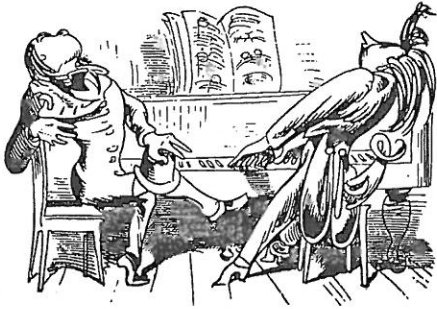

Maestoso.

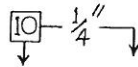

Majestic but also Pompous (♩ = ca. 72)

Musical score for the first system, including treble and bass staves, dynamic marking *ff*, and the instruction *tre corde*.

Musical score for the second system, featuring a *8va bassa* instruction and a *poco accel.* marking.

Musical score for the third system, including *a tempo*, *sub. mp cresc.*, *ff*, *mf dim.*, and *una corda* markings.

Musical score for the fourth system, featuring *a tempo*, *for full*, *sub. ff*, *intenso*, and *loco* markings.

Musical score for the fifth system, including *(8va)*, *clear*, and *8va sempre* markings.

FOR PENSALONLY

poco accel.

(8va) → 6 3

5 fff

4

(8va) → 1/2 (full) clear 3 6

L.H. 6

a tempo

clumsily loco 8va loco

2 ff

4 loco

6 dim.

3 mf

sff

subdued, but with pride

sub.mp

4

poco rit. - *a tempo*

3 sub. ff

mp

4

una corda

pp

3 4

sfff

tre corde

11 1/2"

sub.ppp

holding chord with Pedal, turn the page, then immediately begin to play capriccioso ...

attacca



Capriccioso.

Go! ♩ = 144 (with a "hot jazz" feel)

Handwritten musical notation for the first system, featuring a treble and bass clef with a 4/4 time signature and a forte (f) dynamic marking.

Handwritten musical notation for the second system, including a treble clef, a 3/4 time signature, and annotations such as "bouncy", "8va", and "use H. if possible".

Handwritten musical notation for the third system, featuring a treble clef, a 4/4 time signature, and annotations including "R.H. (♩ = ♩) (Loco)" and "L.H.".

Handwritten musical notation for the fourth system, including a treble clef, a 4/4 time signature, and the annotation "slightly slower, ragtime tempo (♩ = ♩)".

Handwritten musical notation for the fifth system, featuring a treble clef, a 4/4 time signature, and the annotation "Tempo primo".

* see picture above

FOR PERSAL ONLY

5/4 4

p distant; hollow

una corda

dim.

slowly — release — Ped.

2/4

ppp

p — *f* — *gliss* — *ff*

tre corde

acrobatic

R.H. —

L.H. 7

R.H. —

f — *ff*

R.H. —

precise

ff — *p* — *f* *sub.pp*

sub.f

8va

12 1/2"

(move on)

(accel.) →

(cresc.) →

($\frac{1}{4}$ Ped.) →

- (♩ = 80) -

- (f) -

espress.

(accel.) →

- (♩ = 84) -

8va ser...

whirlwind...

(cresc.) →

legato →

- (ff) -

(loco)

- (♩ = 88) -

8va →

legato →

- (♩ = 92) -

- (fff) -

(cresc.) →

- (♩ = 96) -

8va → (G⁴)

13

- (♩ = 112) →

1"

molto

ffffz

attacca

($\frac{1}{4}$ Ped.) →

(secco)

V.S. [^]

* or 8:8, but bring out intervals: 3rd, 4th, 3rd.

[^] page-turn can be loud and assertive!



Fuga del diavolo.

Furioso (♩. = 112 - 116)

12/8 *f*

Ped. ad. lib.

poco cantabile

even
mp *poco - cresc.*

delicato
sub.p *subff*

bring out
(transparent) *cresc.*

"whipcrack" *delicato* *sub. pp* *dolce* *mf* Era -

capriccioso *delicato* *(loco)* *sub. pp* *dolce*

f *8:6* *sub. p* *mf* *dim.* *pp* *cresc.*

mechanical *f* *sub. ff*

The image shows a handwritten musical score for piano, consisting of five systems of staves. The notation includes treble and bass clefs, time signatures (3/8, 6/4, 4/4, 12/8), and various musical symbols such as accidentals, slurs, and dynamic markings. The score is heavily annotated with performance instructions in italics, including 'whipcrack', 'delicato', 'sub. pp', 'dolce', 'mf', 'capriccioso', '(loco)', 'f', '8:6', 'sub. p', 'dim.', 'pp', 'cresc.', 'mechanical', and 'sub. ff'. A large, diagonal watermark 'FOR PENSAL ONLY' is overlaid across the entire page. The page number '23' and the tempo marking '(♩ = ♩)' are located in the top right corner.

The image shows a handwritten musical score for piano, consisting of five systems of staves. The notation includes treble and bass clefs, various time signatures (8:6, 6/4, 12/8), and dynamic markings such as *sub p*, *cresc.*, *ff*, *mf*, *p*, *delicate*, *mf*, *bolder*, and *sudden!*. Performance instructions include *whistling*, *Ped. ad lib.*, and *capriccioso*. The score features complex rhythmic patterns, including triplets and sixteenth notes, and includes a section marked *capriccioso* in 6/4 time. A large, diagonal watermark reading "FOR PERSAL ONLY" is overlaid across the entire page.

12/8

11/8

8:6

cres.

ff

12/8

articulate

sub p

8:6

cres.

♩ = ♩

3/4

8va

ff

14

1"

(,)

attaca

(,)

FOR PERUSAI ONLY



Forte vivace.

(♩ = 112 - 116)

Aggressive, but slightly swing eighth-notes

4/4 *ff sempre*

5/4 *don't slow down*

Sos. *Bouncy...* *sub. p cresc.*

(*Sos.*) (Ped.)

... becoming heavier

ff *Eva* *Eva basso*

The image shows a handwritten musical score for piano, consisting of four systems of music. The notation is in treble and bass clefs. The first system includes a tempo marking $(\text{♩} = \text{♩})$ and features several triplet markings. The second system includes a *Loco* marking and a *8va7* instruction. The third system includes a *Maest. - - a tempo* marking and a *8va7* instruction. The fourth system includes a *secco* marking, an *accel.* marking, a tempo change to $\text{♩} = 240! \rightarrow$, and a *subp cresc.* marking. The score concludes with a *ff* dynamic and an *attacca* instruction. A rehearsal mark $\boxed{15}$ is located at the bottom of the page, with a double bar line and a $2\frac{1}{2}''$ measurement.

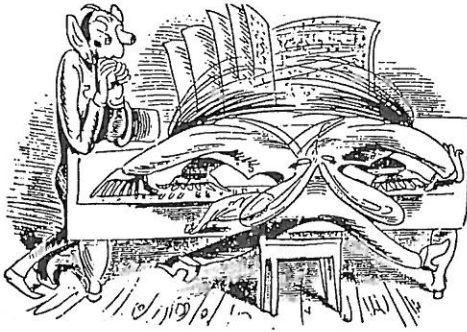

Fortissimo vivacissimo.

(♩ = 240; ♪ = 120)

Driven with intensity; sudden; fearful

Musical notation for the first system, featuring a treble and bass clef with a 3/2 time signature. The music is written in a key with two sharps (F# and C#) and includes various rhythmic values and dynamic markings.

Musical notation for the second system, continuing the piece with a 4/4 time signature. It features complex rhythmic patterns and dynamic markings.

Musical notation for the third system, including a section marked 'sweeping' with a 3/4 time signature. It features a large slur over a series of notes and dynamic markings.

Musical notation for the fourth system, featuring sixteenth-note passages with a '6' marking, indicating a sixteenth-note group. It includes dynamic markings and a large slur.

Musical notation for the fifth system, including a section marked '8va' (octave) and a section described as 'seemingly sporadic, but dead-accurate'. It features a 2/4 time signature and dynamic markings.

FOR PERSAL ONLY

The first system of music consists of two staves. The treble staff begins with a key signature of one sharp (F#) and a common time signature. It contains several chords and melodic fragments, some marked with accents (^) and slurs. The bass staff provides harmonic support with chords and some melodic lines. A 5/4 time signature is indicated in the middle of the system, and a 2/2 time signature appears at the end.

The second system is in 2/2 time. It features a wide intervallic leap in the treble staff, spanning several octaves, with sixteenth-note passages. Fingerings (6) are indicated for the left hand. The bass staff has a similar melodic line. A large slur covers the entire system.

The third system continues the sixteenth-note passages from the previous system. It includes a 5/4 time signature. Fingerings (6) are shown for the left hand. A large slur covers the system.

The fourth system features triplet markings (3) over groups of notes in both staves. Dynamic markings include *sffz*, *p*, and *cresc.*. The time signature is 2/2. A large slur covers the system.

The fifth system begins with a *ff* dynamic marking. It includes a *fff* dynamic marking and the word *secco*. A repeat sign with first and second endings is present. The system concludes with the instruction *attacca*. A large slur covers the system.

FOR PERUSAL ONLY

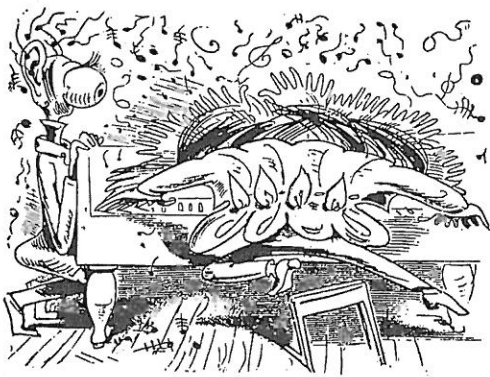

Finale furioso.

Big; Eye-popping (d = 120)

Handwritten musical notation for the first system, featuring a grand staff with treble and bass clefs. The music is in 2/2 time and marked *ff*. It includes sixteenth-note runs in both hands, with a '6' indicating a sixteenth-note group. The bass line has a '7' below it. A dynamic marking 'v' is present at the start.

Handwritten musical notation for the second system, continuing the grand staff. It features sixteenth-note runs and rests. A '3' is written above the treble staff, and a '2' is written below the bass staff. A key signature change to two sharps (F# and C#) is indicated by a sharp sign and a '2' below the bass staff. A dynamic marking 'v' is present.

Handwritten musical notation for the third system. It includes a tempo marking '(♩ = ♩)'. The notation shows sixteenth-note runs and rests. A '3' is written above the treble staff, and a '4' is written below the bass staff. A dynamic marking 'v' is present.

Handwritten musical notation for the fourth system, featuring sixteenth-note runs in both hands. A '6' is written above the treble staff, and another '6' is written below the bass staff. A dynamic marking 'v' is present.

Handwritten musical notation for the fifth system. It includes a '3/4' time signature. A '6' is written above the treble staff, and another '6' is written below the bass staff. A dynamic marking 'v' is present. A 'Ped.' marking with an arrow points to the right. A 'gliss.' marking with an asterisk is written above the treble staff. A 'Sra' marking with an arrow points to a specific note in the treble staff. A dynamic marking 'v' is present.

—(Ped.)→

* white note gliss.

** left arm, black-note cluster

FOR PERUSAI ONLY

ca. 5"

sub. mf cresc. (Ped.) →

intenso; molto; "hammering"

* gliss.

17 1/2"

Bye

fff

molto secco!

* white note gliss. (Ped.) →

(Ped.) →

stand immediately! ...

For Perusal Only

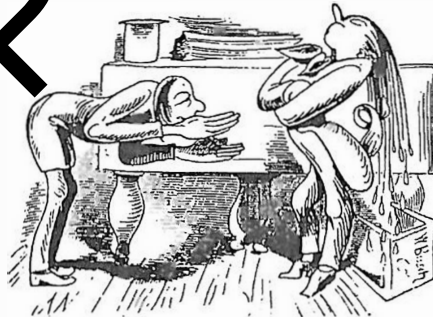

Bravo-Bravissimo.

Ann Arbor, June 30, 1987.